



JDR-34 / JDR-34 F – Radial Drill Presses

- Precision cast iron table
- Lockable magnetic switch
- 1–16mm quick clamping chuck with chuck guard standard
- 80 mm spindle travel with adjustable drill depth stops
- Powerful 400-W induction motor for continuous operation
- 5 spindle speeds 500 – 2500 rpm
- 410 mm max. distance to column
- Head can be tilted 45° to the right and 90° to the left
- Cross laser for easy operation standard

Standard equipment

- 16 mm quick-clamping chuck
- Arbor MT-2/B16
- Chuck guard
- Cross laser with transformer and On/Off switch
- Belt cover with limit switch
- Operating instructions and operating tool

Accessories

Stock number	Description
10000391	Machine stand for JDR-34

Stock number 230 V	10000390 M	10000395 M
Model:	JDR-34	JDR-34 F
Distance spindle column:	155 – 410 mm	155 – 410 mm
Spindle travel:	80 mm	80 mm
Spindle taper:	MT-2	MT-2
Quick-clamping chuck:	1–16 mm	1–16 mm
Column diameter:	60 mm	73 mm
Table size:	220 x 230 mm	Ø 300 mm
Speeds: 5	500 – 2500 rpm	500 – 2500 rpm
Base size:	345 x 210 mm	280 x 480 mm
Motor power: P ₁	0.55 HP/S ₁ 100%	0.55 HP/S ₁ 100%
Weight:	42 kg	61 kg



Left/right-handed rotation on 400-volt JDP-15 and JPD-17 F models

Hinged steel belt and pulley cover for easy access



Quick clamping precision chuck



JDP-10

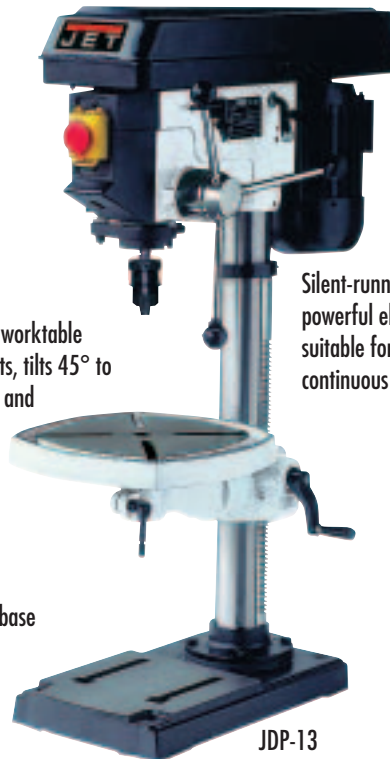

JDP-13



JDP-17 F

Precision worktable with T-slots, tilts 45° to each side and swivels 360°

Silent-running and powerful electric motors suitable for continuous operation

Sturdy, extra large base plates with T-slots



JET Quality control in line with Swiss precision criteria

- Guaranteed concentricity in Morse taper <math><0.03\text{ mm}</math>
- Spindles are supported by precision ball bearings
- Left/right-handed rotation standard on 400-volt models
- Quick clamping precision chucks standard on all models
- Powerful motors for continuous operation
- Standard model JDP-15/17 F with limit switch on belt cover
- Precision drill depth stop standard with all models

Stock number 230 V	10000350 M	10000360 M	10000370 M	10000380 M
Stock number 400 V			10000370 T	10000380 T
Model:	JDP-10	JDP-13	JDP-15	JDP-17 F
Swing:	127 mm	165 mm	190 mm	215 mm
Spindle travel:	60 mm	80 mm	85 mm	85 mm
Spindle taper:	MT-2/B 16	MT-2/B 16	MT-2/B 16	MT-3/B 16
Quick-clamping chuck: 1–16 mm	standard	standard	standard	standard
Column diameter:	59.5 mm	73 mm	73 mm	80 mm
Table size:	210 x 195 mm	270 x 270 mm	330 x 330 mm	365 x 365 mm
Total height:	840 mm	1000 mm	985 mm	1625 mm
Drilling performance in steel:	16 mm	20 mm	22 mm	25 mm
Speeds:	12	12	12	16
Speed range:	210–2580 rpm	210–2580 rpm	210–2580 rpm	160–3030 rpm
Motor power output:	0.33 HP / S ₁ 100%	0.5 HP / S ₁ 100%	0.7 HP / S ₁ 100%	0.75 HP / S ₁ 100%
Motor power input:	0.58 HP/S ₆ 40%	0.88 HP/S ₆ 40%	1.25 HP/S ₆ 40%	1.35 HP/S ₆ 40%
Weight:	43 kg	63 kg	74 kg	83 kg